

ET90

Tracked Conventional Tail Excavators



**WACKER
NEUSON**
all it takes!



offers performance and fuel economy

The minimum swing radius ET90 track excavator offers one of the smoothest and most powerful hydraulic systems available in its class. The 9-ton excavator comes with an air conditioned cab and a choice of short or long dipperstick and is powered by an economical 73.7-hp Deutz Tier 4 Final engine. The ET90 comes standard with rubber tracks, dozer blade and boom-mounted working light. Hydraulic system features an oil cooler, pilot controls and dipperstick-mounted auxiliary connections for single and bidirectional attachments. An in-cab electronic control pattern changeover is standard.

- The unit's compact size, high performance and low center of gravity allow this excavator to work in a variety of applications, especially in confined areas
- The three-pin bucket linkage system provides best-in-class breakout force of 16,636 pounds of force and optimizes the bucket's angle of rotation for digging in tough conditions and to keep the load secure in the bucket before dumping
- Large ergonomically cab design offers operator comfort with 3.5-inch color LCD display, air-ride seat and air conditioning
- Unmatched visibility of the bucket and entire worksite through large windows and front and side lighting, enhancing jobsite safety
- A unique tilting operator's platform and large engine cover are the only two points of access needed to expose all maintenance components

ET90 Technical specifications

Operating data

Shipping weight min.	18,404 lb
Operating weight	19,202 - 22,020 lb
Biting force max.	10,341 lbf
Breakout force max.	16,591 lbf
Digging depth max.	182.1 in
Dumping height	199.4 - 207.6 in
Digging radius max.	300 in
Superstructure slewing speed	9 rev/min
L x W x H	280.2 x 88.6 x 100.9 in

Engine / Motor

Engine / Motor manufacturer	Deutz
Engine / Motor type	TCD 2.9 DOC
Engine / Motor	Liquid-cooled 4-cylinder turbo in-line engine, direct injection, exhaust gas turbocharger and intercooling
Displacement	178.12 in ³
RPM / speed	2,500 rpm
Engine performance according to ISO	74.24 hp
Battery	88 CCA
Fuel tank capacity	22.5 US gal

Hydraulic system

Duty pump	Variable displacement pump
Flow rate	47.69 US gpm
Operating pressure for working and driving hydraulics	4,351 psi
Operating pressure swing gear	3,481 psi
Hydraulic oil tank	24.3 US gal

Undercarriage

Travel speed max.	3.1 mph
Chain width	17.7 in
Ground clearance	14.6 in

Dozer Blade

Stroke dozer blade above subgrade	18.9 in
Stroke dozer blade below subgrade	20.4 in

Sound level

Sound level (LwA) according to 2000/14/EC	99 dB(A)
Cabin - specified sound pressure level LpA according to ISO 6394	79 dB(A)

ET90 Dimensions

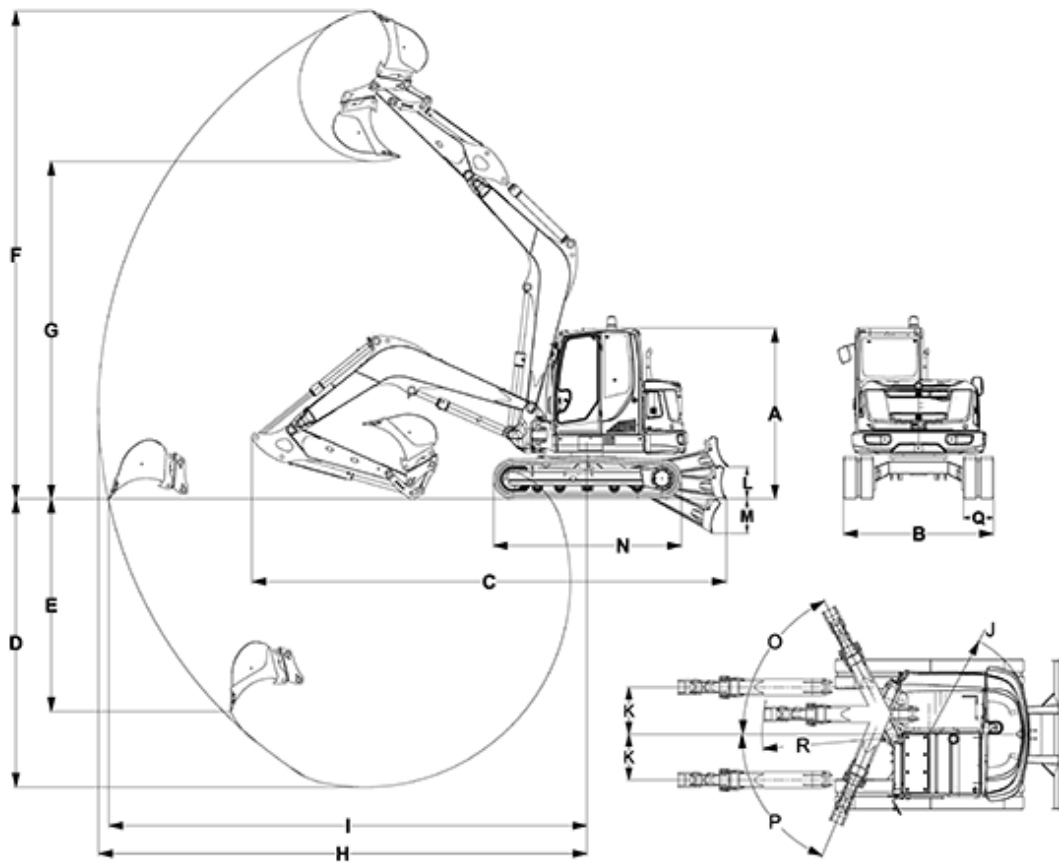

A	Height	100.9 in
B	Width - Cab	39.4 in
B	Width - Revolving superstructure	79 in
B	Width - Chassis	88.6 in
B	Width - Dozer blade	88.6 in
C	Transport length - Standard Dipperstick	280.2 in
C	Transport length - Long Dipperstick	281.1 in
D	Digging depth max. - Standard Dipperstick	170.3 in
D	Digging depth max. - Long Dipperstick	182.1 in
E	Insertion depth - Standard Dipperstick	125.7 in
E	Insertion depth - Long Dipperstick	136.8 in
F	Insertion height - Standard Dipperstick	288.3 in
F	Insertion height - Long Dipperstick	296.4 in
G	Dump height max. - Standard Dipperstick	199.4 in
G	Dump height max. - Long Dipperstick	207.6 in
H	Digging radius max. - Standard Dipperstick	288.6 in
H	Digging radius max. - Long Dipperstick	300 in
I	Range - Standard Dipperstick	282.6 in
I	Range - Long Dipperstick	294.3 in
J	Rear swivel radius - w/o Counterweight	62.3 in

J	Rear swivel radius - with Counterweight	65.2 in
K	Arm displacement to centre of bucket, right side	27.8 in
K	Arm displacement to centre of bucket, left side	26.9 in
L	Lift height -Above ground	18.9 in
M	Scraping depth - Below ground	20.4 in
N	Length - Total traveling gear	111.3 in
O	Turning angle - Boom system to the right	63 °
P	Turning angle - Boom system to the left	67 °
Q	Chain width	17.7 in
R	Boom slewing radius - Middle	98.5 in
--	Boom slewing radius - Right	95.6 in
--	Boom slewing radius - Left	77.5 in
--	Height - Dozer blade	19.7 in

Please note: that product availability can vary from country to country. It is possible that information / products may not be available in your country. More detailed information on engine power can be found in the operator's manual; the stated power may vary due to specific operating conditions. Subject to alterations and errors excepted. Applicable also to illustrations.
 Copyright © 2021 Wacker Neuson SE.