

10.65 HEAVY DUTY

TECHNICAL SHEET



10.65 HEAVY DUTY

TECHNICAL FEATURES

Models		10.65
Dimensions		
[A] Height	mm	2.550
[B] Width	mm	2.334
[C] Track	mm	1.840
[D] Ground clearance	mm	410
[E] Front overhang	mm	1.673
[F] Pitch	mm	2.950
[G] Rear overhang	mm	1.265
[H] Length without tow hook	mm	5.856
[I] Length with tow hook	mm	5.928
[L] Cab width	mm	960
Width with stabilizers	mm	-
Loading system		
Lifting capacity	kg	6.500
Lifting height	m	9,5
Max horizontal boom extension	m	5,4
Boom extension at max height	m	0,45
Number of extracting sections	n.	1
Swinging Angle	°	149
Tank capacity		
Fuel tank	l	120
Adblue tank	l	10
Hydraulic oil tank	l	150
Connection equipment		
Fh		-
FH Heavy		●
Euro		-
Other		
Telematics farmatics		○
Frame lateral levelling 10°		●
Front stabilizers		-
Rear axle swing block		-
Bucket mode		●

Models		10.65
Maximum unladen weight		
Classic 74	kg	11.050
Classic 75	kg	11.050
HLS 74	kg	11.200
VPSe 100	kg	11.250

Models		10.65
Drawbar pull		
Classic 74	daN	8.500
Classic 75	daN	8.500
HLS 74	daN	9.000
VPSe 100	daN	10.400

Models		10.65
Tyres		
Turning radius	m	4,5
445/65-R22 OFFSET+40		●
18-22.5 MPT06 OFFSET +40		○
375/85-24 CAMSO 783S OFFSET +10		○
445/65 R22.5 AEOLUS AE77		○

● Standard ○ Optional - Not available

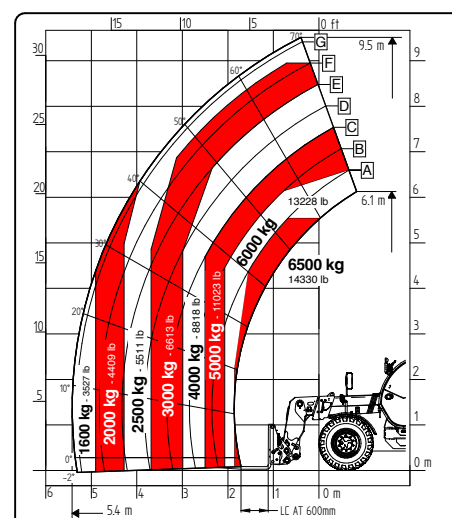
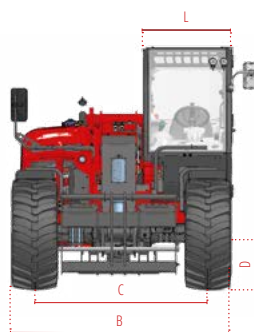
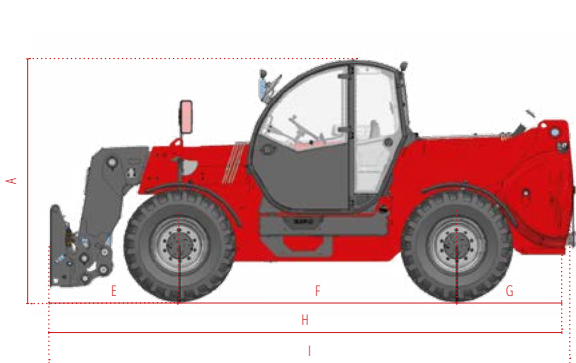

10.65

10.65 HEAVY DUTY

CONFIGURATIONS

Configurations	Classic 74 / Classic 75	HLS 74	VPSe 100
Engine			
Deutz 74/101	<input type="checkbox"/> STAGE IIIA <input type="checkbox"/> STAGE V kW/hp ●	●	-
Deutz 100/136	<input type="checkbox"/> STAGE V kW/hp -	-	●
Engine water preheating	○	○	○
Post-treatment system (only Stage V)	DOC/DPF + SCR	DOC/DPF + SCR	DOC/DPF + SCR
Radiator fan	Mechanical	Mechanical	Mechanical
Hydraulics			
Pump type	Gears	LS piston	LS piston
Hydraulic flow-rate	l/bar 120/230	152/250	180/250
Flow sharing distributor	-	●	●
Eletro-proportional joystick	Mechanical	Hydraulic	Hydraulic
Quick release	○	○	●
Boom suspension	○	○	○
Floating boom	○	○	○
Lifting valve	-	Ecofast	Ecofast
Regenerating valve up hill	-	●	●
Manual 6-way diverter valve	○	○	○
Constant front flow	○	○	○
Creeper	○	●	●
Boom Electric Socket (PEB)	○	○	○
Electronic boom speed control	-	○	○
Transmission			
Hydrostatic two mechanical gears 40 km/h	●	●	-
Hydrostatic continuous variation 40 km/h	-	-	●
Axles			
45% limited slip self-locking differential front axles	●	●	●
Open type differential rear axles	●	●	●
Brakes			
Service brake		Multi-disc in oil bath	
Parking brake		Multi-disc in oil bath with negative drive type SAHR	
Pneumatic / hydraulic trailer brake	○	○	○
Lights			
Front lights	●	●	●
Rear lights	●	●	●
Front and rear work lights	○	○	○
Boom work lights	○	○	○
Rear trailer lights socket	○	●	●
Cabin			
Cabin	Standard	Standard	Standard
Protection grille for windscreen	○	○	○
Colour display	" 3,5	3,5	3,5
Start and stop system (IAS)	○	○	○
Air conditioning	○	○	●
Other			
Tow hook	○	●	●

● Standard ○ Optional - Not available

TELEHANDLERS **NEXT GENERATION**



**FARESIN INDUSTRIES SPA
HEADQUARTERS**

Via dell'Artigianato, 36
36042 Breganze (Vicenza), Italy
Tel. + 39 0445 800300
faresin@faresin.com

FARESIN DEUTSCHLAND GMBH

Steinach B.R. - an der
Frankenhoehe 1
91605 Gallmersgarten, Germany
Tel. +49 9843 9802828
lager@faresin.de

**FARESIN DEUTSCHLAND
NORD GMBH**

Wissmannstr, 59
27755 Delmenhorst, Germany
Tel. +49 4221 800 989-0
info@faresin-nord.de

FARESIN POLAND SP. Z O.O.

ul. Borowiacka 9
87-100 Torun, Polska
Tel. +48 503 147 811
poland@faresin.com

**FARESIN INDUSTRIES
FRANCE**

2 Rue de l'Avenir 14460
Colombelles, France
Tel + 33 2 31 82 79 61
france@faresin.com

It brings to the attention of all potential customers, all recipients, and to the maximum extent possible, external interlocutors, that Faresin Industries S.p.A. adopts a general Disclaimer regarding the description of the technical and functional characteristics of its machineries, as well as the manner of their use, also with regard to their safety. The Disclaimer must be understood as having a general scope, and therefore Faresin Industries s.p.a. invites to know it, also by accessing the website: faresin.com

FARESIN.COM



04.2025